

# MODEL NO. 424-2

## ASSEMBLY INSTRUCTIONS (XB)

Made in China

Thank you for purchasing this quality product. Be sure to check all packing material carefully for small parts which may have come loose inside the carton during shipment. Separate, identify, and count all parts and metal hardware. Compare with parts list to be sure all parts are present. If any part(s) are missing or damaged, phone, fax, or mail to our Customer Service Department. For efficient and speedy service, please indicate the model number and code letter of part(s) needed.

**IMPORTANT NOTE:** Follow instructions listed below in the proper sequence as numbered to assure fast, easy and correct assembly.

### PARTS

(A) LEFT BASE END PANEL	(G) LARGE LID	(M) LONG WOOD SCREWS (28)	(R) LARGE DOWELS (24)
(B) BASE BACK PANEL	(H) SMALL LID	(N) SHORT WOOD SCREWS (23)	(S) HOOKS (5)
(C) BASE FRONT PANEL	(I) LEFT BACK PANEL	(O) CAM-BOLTS (18)	(T) LID STAY
(D) BOTTOM	(J) RIGHT BACK PANEL	(P) CAM-LOCKS (18)	(U) CENTER PANEL
(E) LEFT SIDE PANEL	(K) TOP BACK PANEL	(Q) COVERS (18)	(V) SMALL DOWELS (4)
(F) RIGHT SIDE PANEL	(L) TOP PANEL		(W) RIGHT BASE END PANEL

### HARDWARE ILLUSTRATIONS

Tools required: Screwdriver

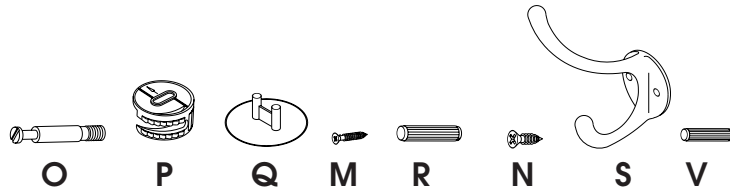

**ATTENTION:** SOME NUMBERED PARTS LISTED ON THE INSTRUCTION SHEET MAY NOT BE IN PARTS BAG AS THEY MAY ALREADY BE ASSEMBLED. CAREFULLY CHECK PARTS AND PACKING MATERIALS PRIOR TO ORDERING REPLACEMENTS.

- Note:** Upon opening, thoroughly clean all wood surfaces with furniture polish to remove dust and dirt that may have settled onto finish during shipment.
- Place parts on a soft cloth. Tighten Cam-bolts (O) into threaded holes in Base End Panels Left and Right (A,W). Insert Small Dowels (V) into center holes in End Panels (A,W). Insert Cam-bolts (O) and Small Dowels (V) extending from End Panels (A,W) into ends of Front and Back Base Panels (B,C). Insert Cam-locks (P) into large holes in Front and Back Base Panels (B,C) with slot for screwdriver facing outward. Rotate Cam-locks (P) clockwise to secure Cam-bolts (O). Insert Covers (Q) into Cam-locks (P). (See ill. #1)
- Insert Bottom (D) into assembled frame of base. (See ill. #2)
- Insert Large Dowels (R) into holes between Right and Left Back Panels (I,J). Insert Long Wood Screws (M) through Center Panel (U) and tighten into Right and Left Back Panel (I,J). Tighten Cam-bolts (O) into threaded holes in bottom edge of Top Back Panel (K). Insert Large Dowels (R) into non-threaded holes in Top Back Panel (K). Insert Cam-bolts (O) and Large Dowels (R) extending from Top Back Panel (K) into top edge of Left and Right Back Panels (I,J) with mirrored side facing front. Insert Cam-locks (P) into large holes in Left and Right Back Panels (I,J) with slot for screwdriver facing outward. Rotate Cam-locks (P) clockwise to secure Cam-bolts (O). Insert Covers (Q) into Cam-locks (P). (See ill. #3)

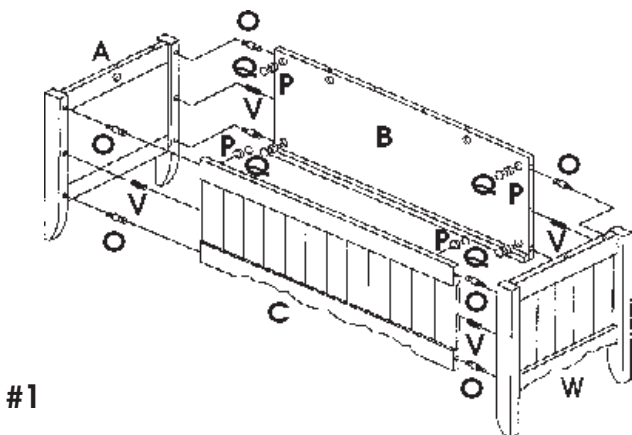

#1

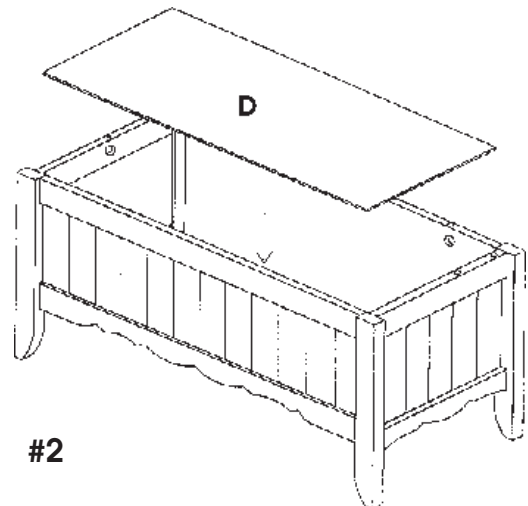

#2

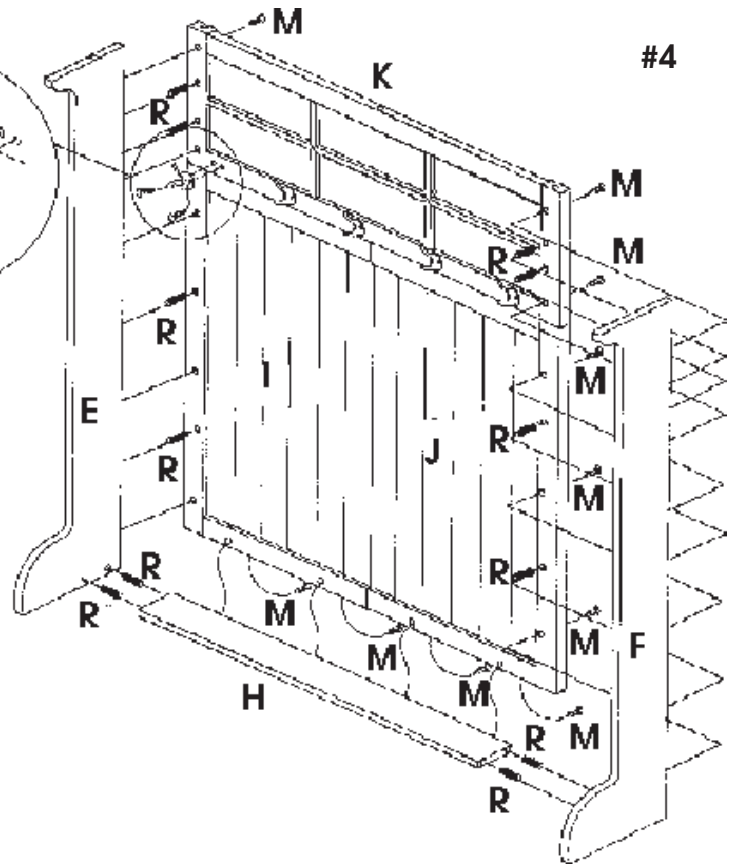
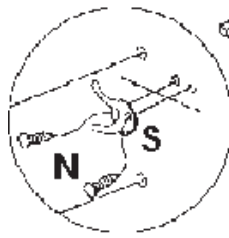
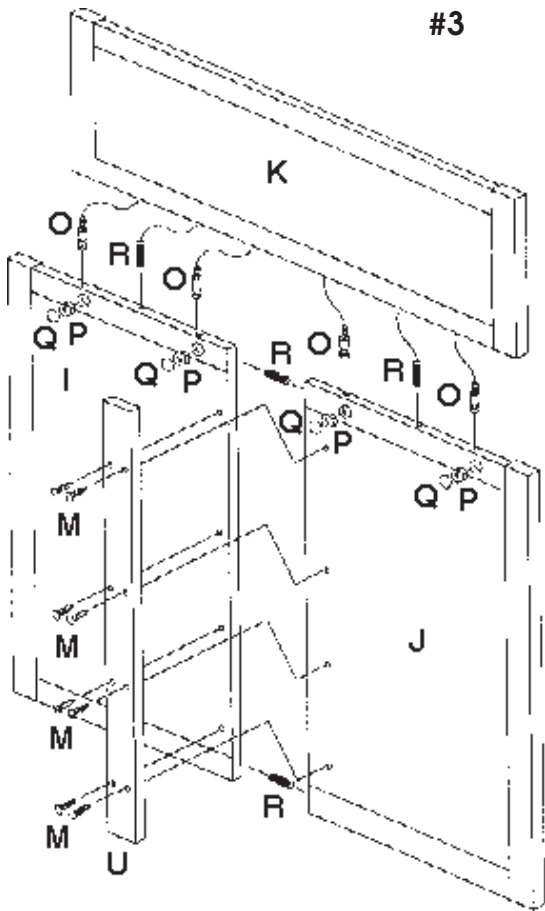

5. Insert Large Dowels (R) into rear edge, and inside edge of Left and Right Side Panels (E,F). Insert DLarge Dowels (R) extending from Left and Right Side Panels (E,F) into left and right ends of Small Lid (H). Insert Large Dowels (R) extending from Side Panels (E,F) into front side of Left, Right, and Top Back Panels (I,J,K). Insert Long Wood Screws (M) through Left, Right, and Top Back Panels (I,J,K) and tighten into Side Panels (E,F) and Small Lid (H). Insert Short Wood Screws (N) through Hooks (S) and tighten into lower front edge of Top Back Panel (K). (See ill. #4)
6. Tighten Cam-bolts (O) into threaded holes on bottom edge of Left and Right Back Panels (I,J) and Side Panels (E,F). Insert Large Dowels (R) into remaining holes on bottom edge of Left and Right Back Panels (E,F,I,J). With an assistant, lift assembled Back Panels (E,F,H,I,J,K) and insert Cam-bolts (O) and Large Dowels (R) extending from Back and Side Panels (E,F,I,J) into top edge of Base Back Panel (B) and Base End Panels (A,W). Insert Cam-locks (P) into large holes in Base Back and End Panels (A,B,W) with slot for screwdriver facing outward. Rotate Cam-locks (P) clockwise to secure Cam-bolts (O). Insert Covers (Q) into Cam-locks (P). Insert Short Wood Screws (N) through hinges attached to Large Lid (G) and tighten into Small Lid (H). (See ill. #5)
7. Insert Large Dowels (R) into top edge of Top Back and Side Panels (E,F,K). Align holes in Top Panel (L) with Large Dowels (R) and press downward. Insert Long Wood Screws (M) through Top Panel (L) and tighten into top edge of Top Back and Side Panels (E,F,K). (See ill. #6)

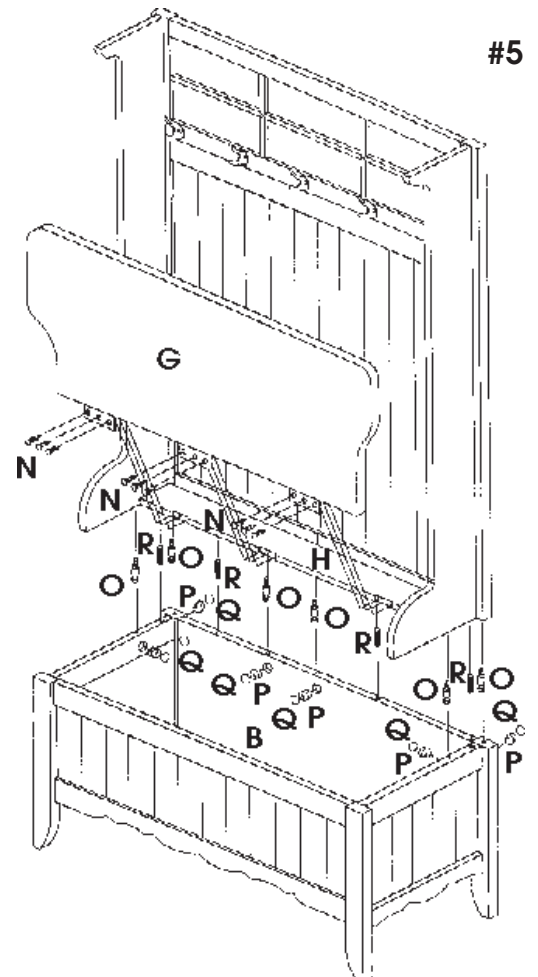

8. Insert Short Wood Screws (N) through Lid Stay (T) and tighten into Right End Panel (W) and underside of Large Lid (G). (See ill. #7)
9. Your furniture has been handcrafted and skillfully finished by fine craftsmen. Rich, deep antique finishes have been applied which require very little polish. However, should you desire a shinier finish, simply use any good grade of furniture polish, rubbing the finish lightly as it is being applied. Allow to dry and buff lightly with a soft cloth.

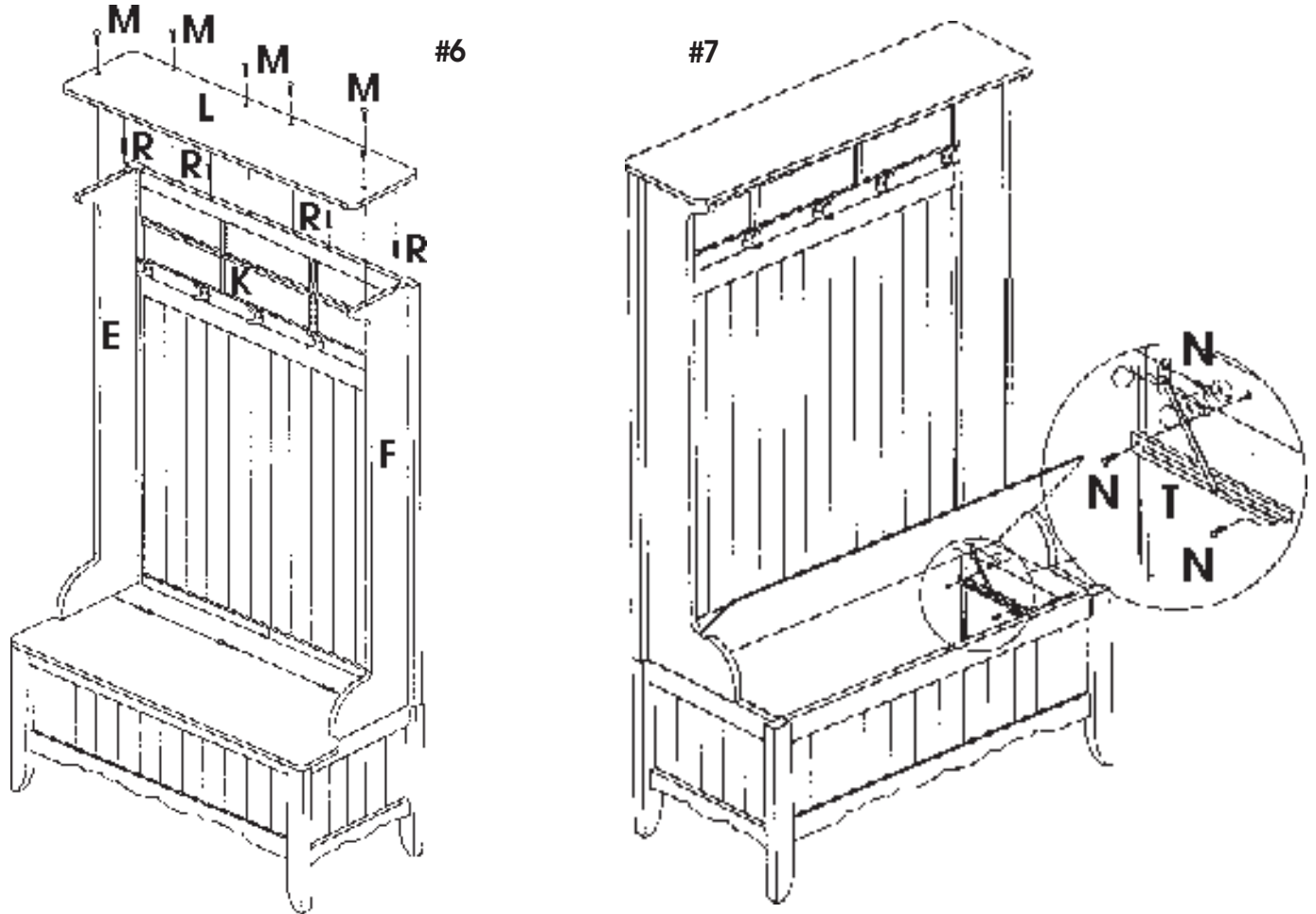

***If you have a problem, we want to have the opportunity to make it right!***

Should there be any missing or defective part(s),

**PLEASE DO NOT RETURN THIS PRODUCT TO THE STORE**

*(Many problems can be resolved without returning this product to the retailer)*

**Model No.**

**424-2**

© 1999

**FAX this form to (310) 841-0842**

or call Customer Service at (800) 622-4456 or (310) 204-2224  
Have your model number and part code letter handy.

Name \_\_\_\_\_

Address \_\_\_\_\_

Daytime Phone (      ) \_\_\_\_\_

Reason for Replacement \_\_\_\_\_

Place of Purchase \_\_\_\_\_

Part Letter	Description	Quantity

P.O. Box 1408, Culver City, CA 90232-1408

Made in China